

**Multi-way ball valve
for process or transfer line
and all types of fluids**

MV[®]

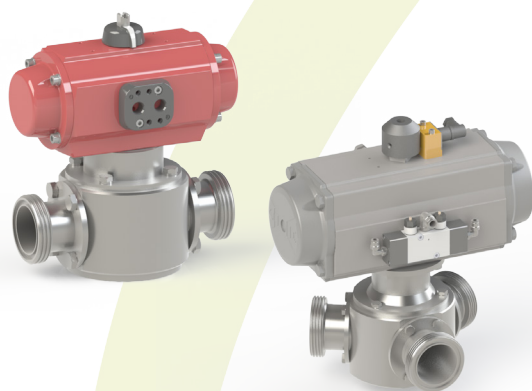

Optional :



Gaskets :



OVERVIEW:

The multi-way ball valve is designed to close one or more circuits or distribute the pressurised fluids to one or more ways. The MV valve comprises a body with 2 or 4 ways and a key (cylindrical ball) which directs the fluid circulation. Its hygienic design ensures there is no retention zone while providing maximum cleanability by hammering during the CIP cycles.

This valve is intended for circuits carrying group 2 clear or viscous liquids (Article 13 of the European directive 2014/34/CE) and solid bearing liquids.

KEY BENEFITS:

- ▲ Full flow (pigging version)
- ▲ Minimisation of pressure losses
- ▲ 2 to 5 ways enabling line pooling for several products
- ▲ Hygienic design
- ▲ Numerous options to meet all types of requirements

APPLICATIONS:

- ▲ Equipment adapted to the lines distributing all types of fluids, including viscous, solid bearing and/or solidifying fluids (creams, chocolate, caramel, etc.)
- ▲ Equipment especially adapted to lines with pigging systems: may be used as a distribution or isolation valve or as intermediary station (pigging receiving version)

AVAILABLE VERSIONS:

The valve body can have 2 to 4 ways, as well as a key (cylindrical ball) which directs the fluid flow:

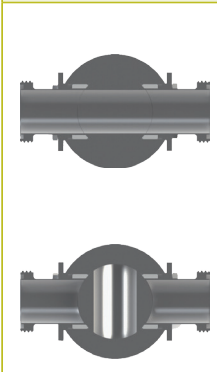
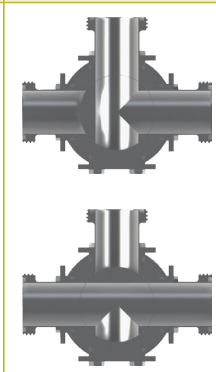
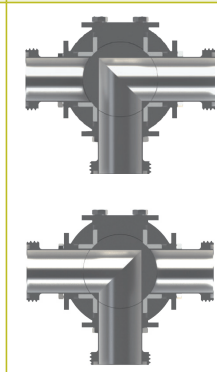
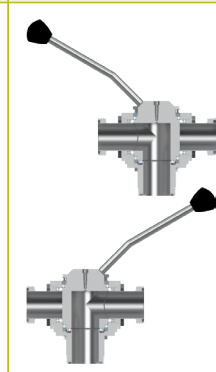
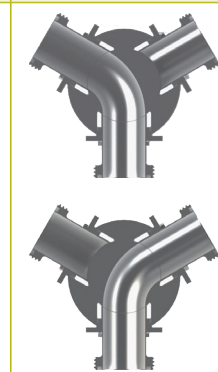
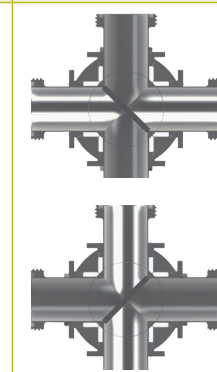
MVA	MVB	MVC	MVD	MVH	MVI
					
On-off valve	90° T-key	90° L-key	Distribution L-key Product entry rear channel	120° L-key	90° L/L-key 2 I/O

TECHNICAL SPECIFICATIONS:

Sizes:

- **SMS:** 25mm (1"), 38mm (1.1/2"), 51mm (2"), 63.5mm (2.1/2"), 76.1mm (3"), 104mm (4")
- **DIN 11851:** DN10, DN15, DN20, DN25, DN32, DN40, DN50, DN65, DN80, DN100, DN125, DN150

Connection:

Male

Product pressure: Empty 10 bar

Service temperature: From 1 °C to 120 °C

Materials:

- Parts in contact with the product: 1.4404 (316L) stainless steel
- Other parts: 1.4301 (304L) stainless steel
- Sealing: Rings PTFE (Polytetrafluoroethylene, eq. Teflon®) and EPDM (Ethylene Propylene Diene Monomer) gaskets

Standard Ra of the valves is 0.8 µm interior.

The DN10 to DN65 standard valves have an operating lever. Models DN80 and DN100 have a double operating lever. As of DN80, we recommend a pneumatic or electric actuator.

All the valves are marked on the lower part of the key; this indicates the exact position of the ways.

Servinox makes every effort to update its documents in line with improvements to its products.

STANDARD DIMENSIONS IN MM:

SIZES	DN10	DN15	DN20	DN25 SMS25	DN32
A	25	28.5	31.5	34	40.5
B	20	24.5	26	29.5	35.5
C	55	63.6	78.1	78	78
E	64	55	98	115	101
F	71	71	110	135	146

SIZES	DN40 SMS38	DN50 SMS51	SMS63.5	DN65	DN80 SMS76.1
A	49	57.5	65.5	65.5	78.5
B	43	50	58	58	67.5
C	96.2	107	123	117	139
E	155	155	198	198	250
F	160	205	265	265	295

SIZES	DN100 SMS104	DN125	DN150
A	89	-	-
B	81.5	110	134
C	160	292	390
E	265	-	-
F	295	-	-

Note: The MVH model is only available from DN25

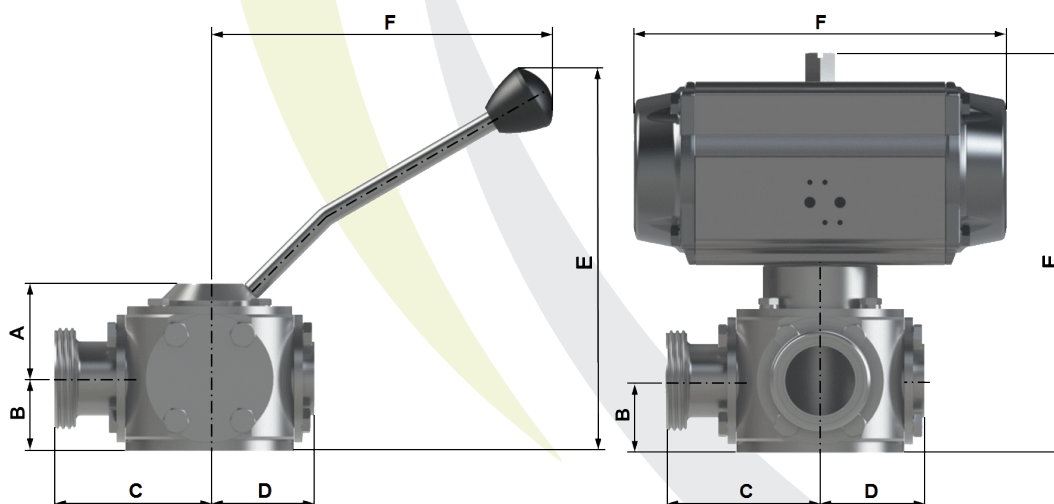

Non contractual document and pictures, subject to change with no prior notice.
Only the commercial offer and the technical manual supplied with the equipment may be used for technical and legal purposes.

OPTIONS :

- Compliant with « ATEX 2014/34/UE zones 1 & 2, gas and dust»
- Handle operating stop: avoid any risk of fluid mix and uncontrolled operations
- Position detection for controller (inductive sensors)
- Automatic version
- Accessories (EV, ED, detection, etc.)
- Pigging distribution or receiving versions
- Heating element
- Intensive cleaning version
- Other connections: To weld, clamp, female, flange
- Sealing - other materials available for rings: Polyethylene, PTFE glass-filled, PTFE filled
- Stainless steel
- Sealing - other materials available for gaskets: NBR (Nitrile rubber), FKM (Fluorocarbon rubber, eq. Viton®), VMQ (Silicone), VMQ PTFE encapsulated (Polytetrafluoroethylene, eq. Teflon®), FFKM (Perfluoroelastomer, eq. Kalrez®)
- Sealing USP Class VI compliant
- Specific surface state
- Other construction materials nuances
- Customised equipment: please contact us

GUARANTEE:

12 months from the date of shipment (except in the case of special conditions)

CONFORMITÉS :

- Elastomer gaskets compliant with **FDA CFR 21.177.2600** and **1935/2004/EC** ruling
- Optional: Gaskets **USP Class VI** compliant
- Optional: Compliant with « ATEX 2014/34/UE, zones 1 & 2, gas and dust»

SERVINOX follows the recommendations of international guidelines and standards relative to hygienic design and construction, in particular those of the EHEDG and 3-A.