



Centrifugal Pumps

CN series

Standard design

Closed coupled single-stage centrifugal pumps. A range of 3 models with open impellers, independent shafts and IEC standard motors.

Optimised design to ensure high levels of hygiene - The absence of product hold-up and no dead-legs ensures efficient cleaning by standard CIP methods and effective sterilisation by SIP.

Wetted parts are in forged polished plate and investment cast electropolished CF3M 1.4409 / AISI 316L (1.4404) stainless steel.

Investment cast and electro-chemical polishing. Internal finishes of 0,5 micron Ra are available on request.

Flow rates up to 75 m³/h, heads of more than 60 m.
Maximum inlet pressure : 4 bar.
Temperature range: -10°C to 120°C.

Seals:

Hygienic mechanical seals with seats to EN 12756, ISO 3069 standards.

Elastomers (certified to US FDA):

EPDM
Fluorocarbon (Viton)
Silicone
P.T.F.E. (FEP)

Connections:

DIN - SMS - IDF - BS / RJT - DS - CLAMP and EN 1092-1 PN16 flanges and on request available for other international standards.

Applications

Food processing, dairy, beverage, chemical, cosmetics and pharmaceutical industries. The open impeller allows a large range of products such as purified water, juices, creams, ice-cream mix, milk, wine, spirits, whey and WFI to be safely transferred.



Pump with shroud and stainless steel adjustable feet.



Pump with B34-B35 motor and stainless steel motor shims.



Open impeller with reversed blades with vast expansion designed to optimize the hydraulic efficiency.

GENERAL DIAGRAMS

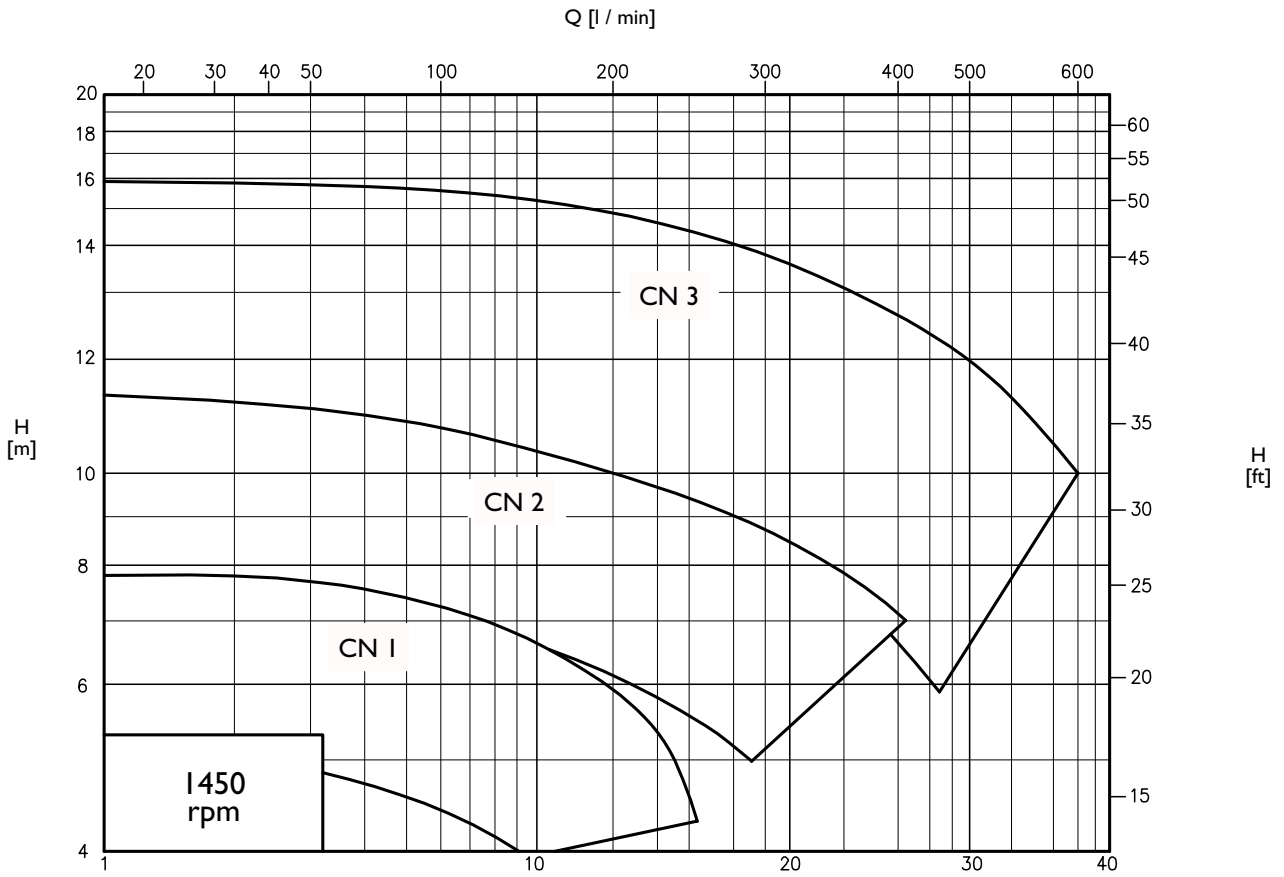

Performance applies to H₂O at 20 °C, 1013 millibar

Q [m³ / h]

Data not binding

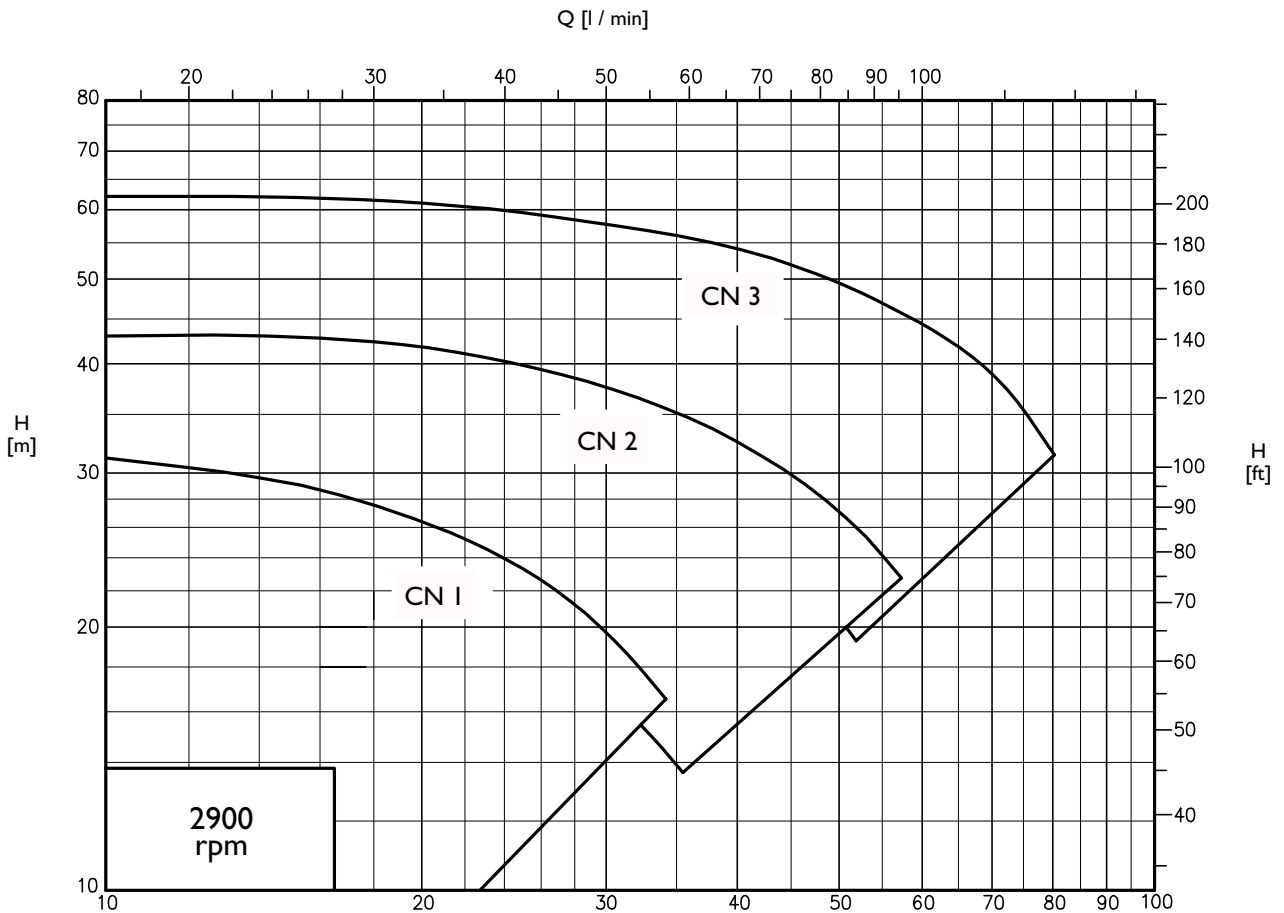

Performance applies to H₂O at 20 °C, 1013 millibar

Q [m³ / h]

Data not binding

All stainless construction, with standard B34-B35 motor; separate pump shaft with clamp coupling, internal product seal and an open impeller.

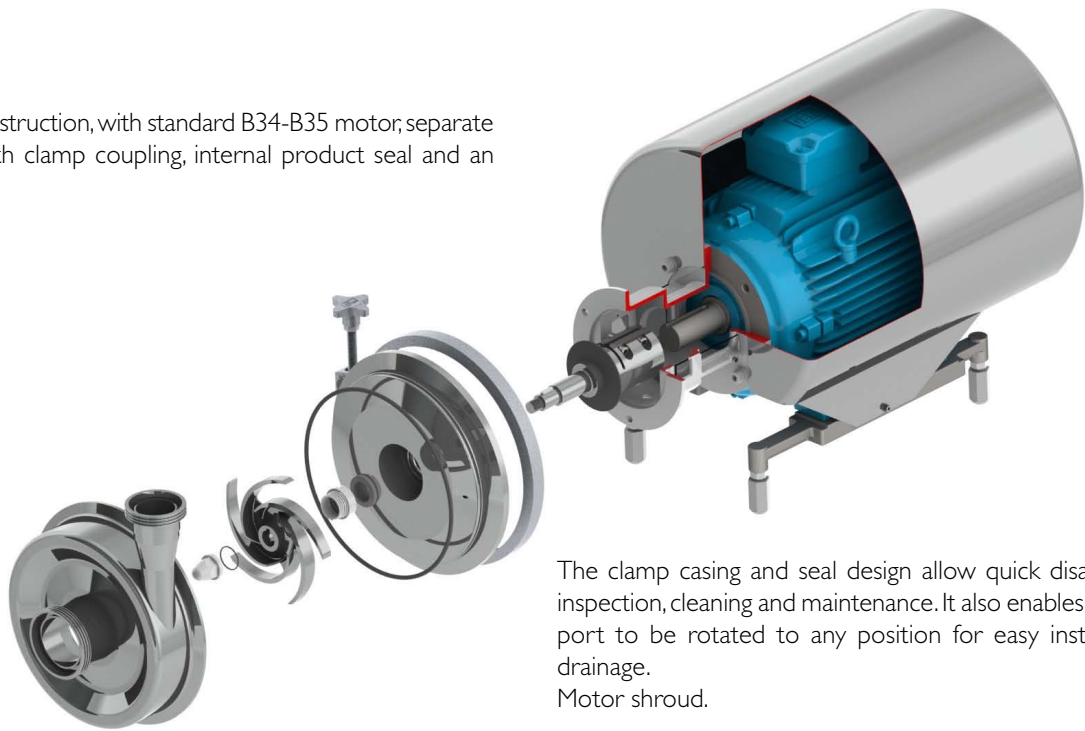

The clamp casing and seal design allow quick disassembly for inspection, cleaning and maintenance. It also enables the delivery port to be rotated to any position for easy installation and drainage.
Motor shroud.

OVERALL DIMENSIONS

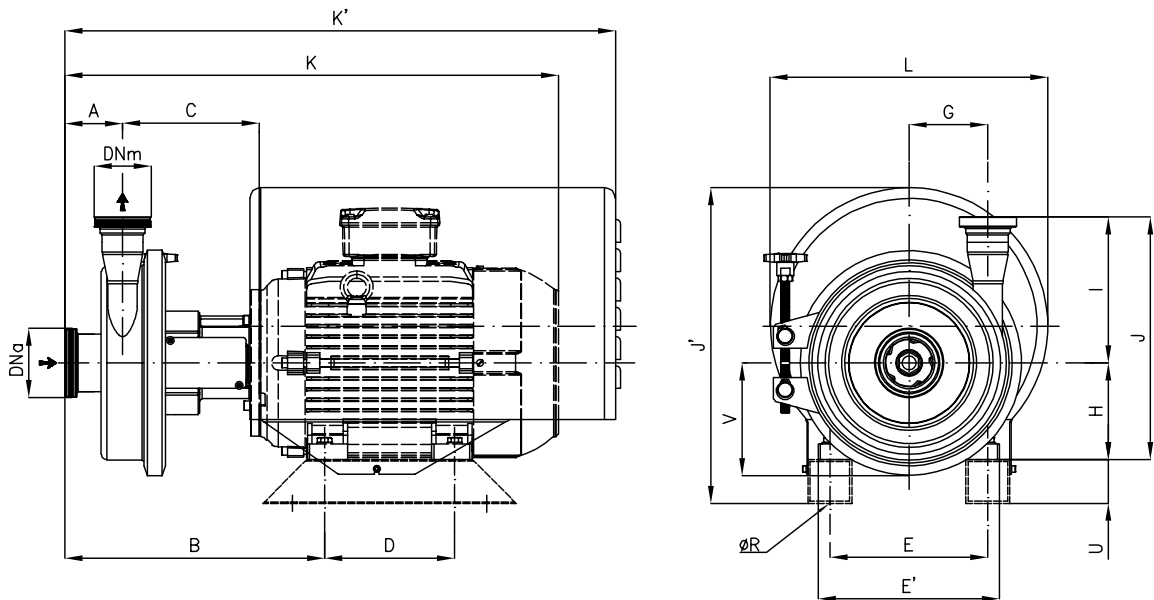

Dimensions not binding - DN = DIN 11851 male threaded connections with standard IEC/EN motors

Pumps	IEC motors size:	DNa	DNm	A	B	C	D	E	E'	G	H	K	K'	ØR	I	J	J'	L	U	V
CN 1	80	50	40	73	277	153,5	100	125	155	86	80	463	584	10	183	263	286	303	40	127
	90				282,5			140	165		90	501	597			273	318			
	100				319,5	183,5	140	160	196		112	591	673	12		283	389	369	50	
	112				190		226	132	627		744	295	402	315		412	380	60		
	132 S				357,5		178	216	256		315	412	380	60						
CN 2	80	65	50	79	286	157	100	125	155	108	80	472	593	10	200	280	286	303	40	154
	90 S				292		140	165	90		508	606	290			317	369			
	90 L				125	190	226	112	598		683	312	400	369		50				
	100				329	140	160	196	132		635	753	332	432		380	60			
	112				187	190	226	160	673		753	360	528	473		50				
	132 S				355	140	216	256	160		778	911	15	360		528	473	50		
	132 M				178	216	256	160	778		911	15	360	528		473	50			
160	404	217	254	300	160	778	911	15	360	528	473	50								
CN 3	90 S	80	65	81	296	159	100	140	164	129	90	519	609	10	255	345	318	303	40	179
	90 L				125		160	100	585		687	369	50							
	100				189	140	190	112	604		687	369	50							
	112				140	190	132	640	757		12	387	432	380		60				
	132 S				358,5	188,5	178	216	256		132	678	757	12		387	432	380	60	
	132 M				178	216	256	160	784		915	15	415	588		473	50			
160	407,5	218,5	254	254	300	160	784	915	15	415	588	473	50							

OVERALL DIMENSIONS

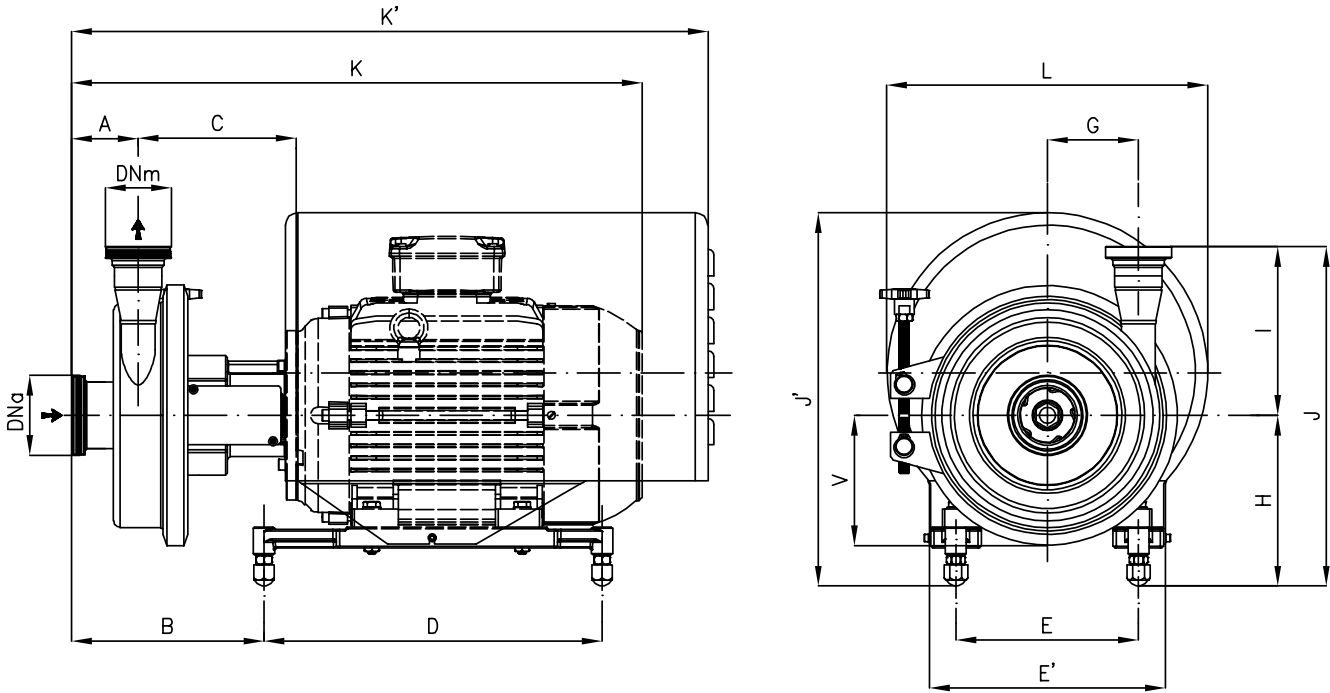

Dimensions not binding - DN = DIN 11851 male threaded connections with standard IEC/EN motors

Pumps	IEC motors size:	DNa	DNm	A	B	C	D	E	E'	G	H	K	K'	I	J	J'	L	V								
CN 1	80	50	40	73	210	153,5	270	138	213	86	160	463	584	183	350	333	303	127								
	90											501	597						343	348	303					
	100											170	572						673	353	409	369				
	112																						182	591	365	422
	132 S																						202	627	744	385
CN 2	80	65	50	79	219	157	270	140	213	108	185	472	593	200	367	333	303	154								
	90											508	606						385	372	303					
	100											194	580						683	394	433	369				
	112																						206	598	406	445
	132 S											202	635						753	402	442	380				
	132 M												673													
160	211	778	911	411	528	473																				
CN 3	90	80	65	81	223	159	270	140	213	129	185	519	609	255	438	372	303	179								
	100											585	687						449	433	369					
	112											205	604						757	460	433	369				
	132 S																						227	640	757	482
	132 M											211	784						915	466	528	473				
	160																						678			



CSF Inox S.p.A. Strada per Bibbiano, 7 - 42027 Montecchio E. (RE) - ITALY EU
 Ph +39.0522.869911 | ra. - Fx +39.0522.865454 / 866758 - csfitalia@csf.it - www.csf.it

Export Department • Commercial Étranger • Comercial Extranjero
 Ph +39.0522.869922 - Fx +39.0522.869841 - csfexport@csf.it - www.csf.it

All the instructions, data and representations (in whatever way executed) listed in this publication are indicative and do not binding. CSF does not stand surety or undertake any obligation for the utilisation of this document and for the information contained. In particular, it does not guarantee against omissions or errors of the data and drawings here indicated.
 Notice that the technical specifications, information and representations in this document are merely indicative and approximate. CSF INOX reserves the right at any moment and without notice to modify the data, drawings and information indicated in this document.