

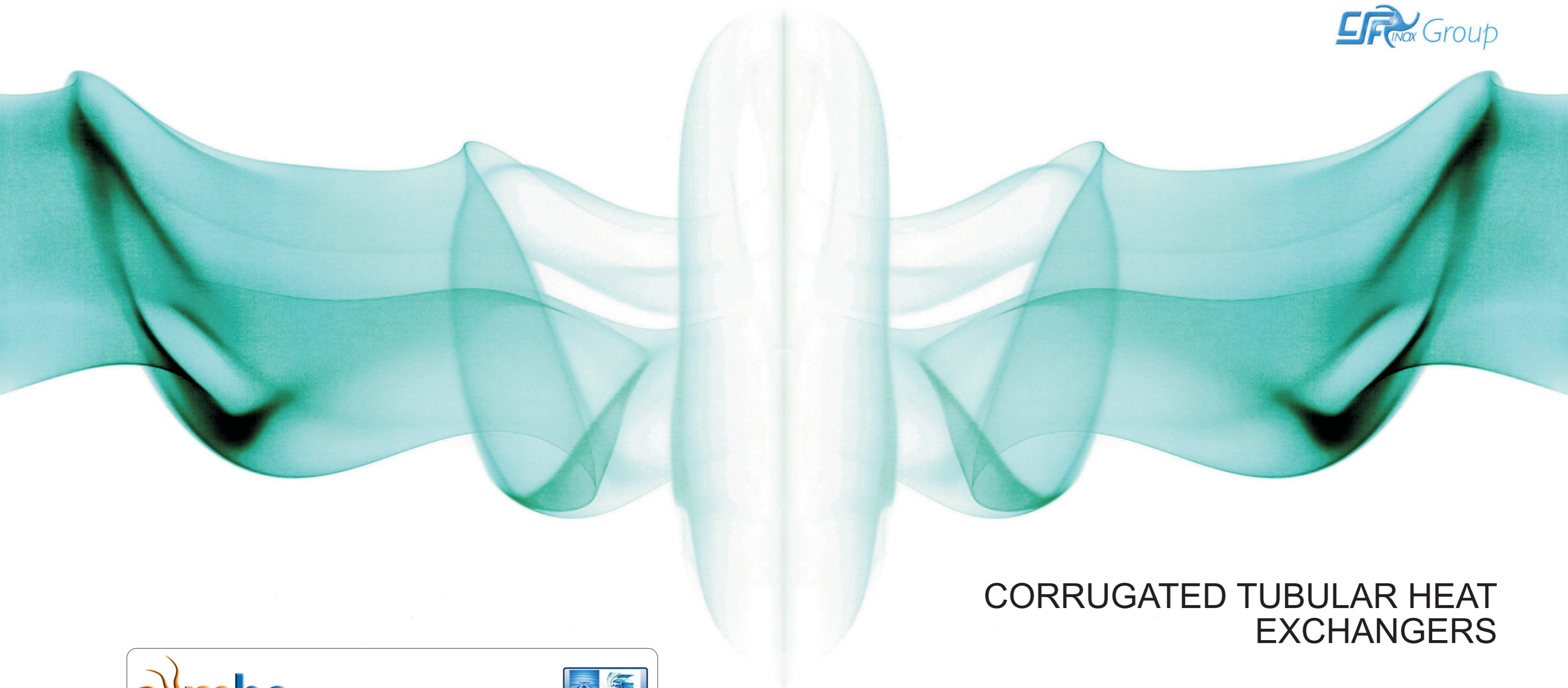

MULTIFLO

MULTITUBE INDUSTRIAL SERIE



CORRUGATED TUBULAR HEAT EXCHANGERS



MBS s.r.l Sede: Str. Martinella 96/b – 43124 PARMA Tel +39 0521.39.71 – Fax +39 0521.64.90.85
Stabilimento: Via degli Olmi – 31010 GODEGA DI SANT'URBANO – TREVISO
www.mbs-europe.com e-mail: mbs@mbs-europe.com



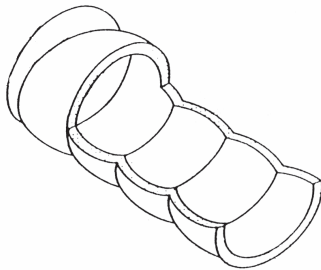

THE CORRUGATION

Corrugation is a particular processing applied on plain tubes to induce dynamic turbulence during the liquids flowing allowing thermal exchange optimization.

With corrugated tubes the thermal exchange efficiency can be enhanced by 40% up to 90% according to the following parameters:

- type of product
- selected profile
- type of application

ADVANTAGES

- reduced exchange surfaces
- reduced contact and standing product time inside the element
- reduced washing time thanks to a higher action produced by turbulence
- vertical or horizontal installation
- working possibilities with high pressures and temperatures
- gaskets-free design so lower maintenance costs
- easy to install and exchanger modularity

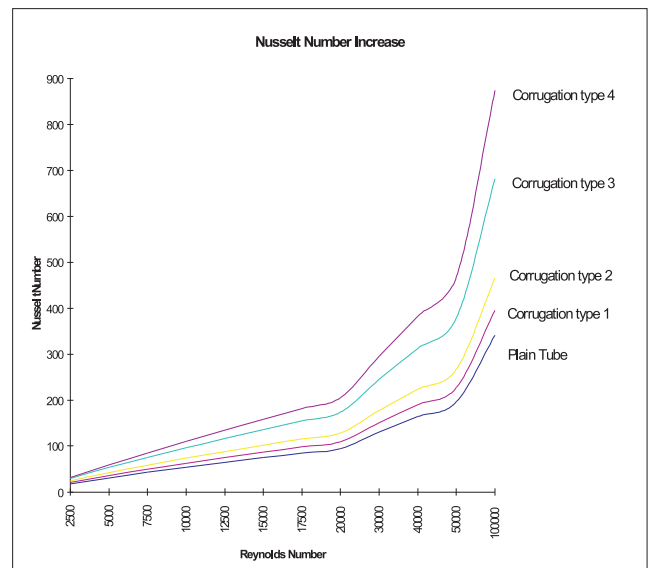

MULTIFLO Heat Exchanger consists of small diameter corrugated tubes fitted inside an external jacket and welded on tube plates at end sides. MULTIFLO is a multipassage / many passages heat exchanger and tubes side backflow is allowed by special heads.

An expansion joint is fitted on external jacket. The product to be thermally processed flows inside small diameter tubes while service fluid flows inside the (external) jacket.

MULTIFLO Heat Exchanger is fully welded.

Application range

Particularly suited for thermal exchange process of industrial products having a low or medium viscosity even with particulates.

Standard materials

Stainless steel AISI 304 / 316 L
(Other kind of materials are available on request)

Standard pressure project

10 bar
(Higher pressures are available depending on utilized connections)

Standard temperature project

184° C

Connections

FLANGE UNI-DIN-ANSI

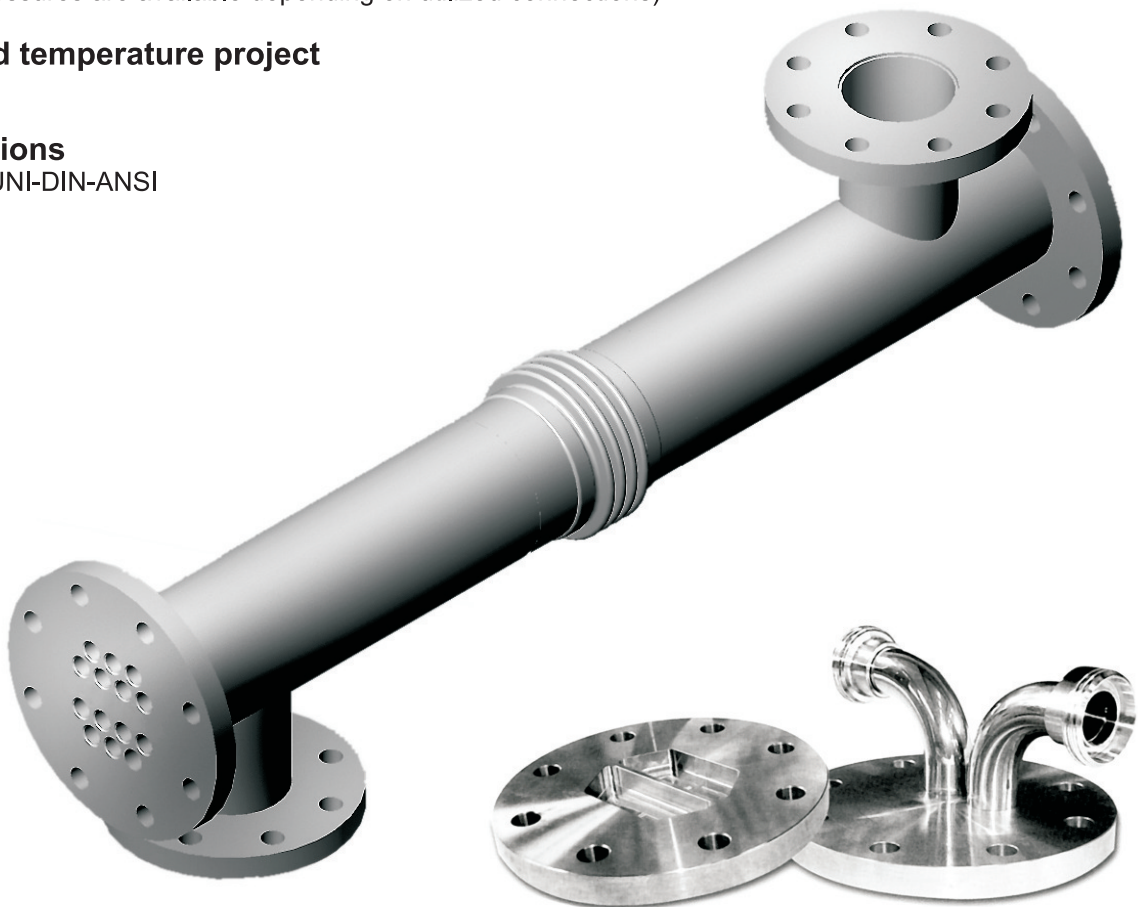

MODEL	SHELL VOLUME [litres]	TUBES VOLUME [litres]	EXCHANGE AREA [m ²]	SHELL SECTION [mm ²]	TUBES SECTION 2 PASSAGES [mm ²]	TUBES SECTION 4 PASSAGES [mm ²]	WEIGHT [kg]
MLM 76 n 12 12 1 1000	2.94	0.86	0.41	2725.7	471.2	235.6	9.5
MLM 76 n 12 12 1 1500	4.30	1.33	0.64	2725.7	471.2	235.6	12.9
MLM 76 n 12 12 1 2000	5.67	1.80	0.87	2725.7	471.2	235.6	16.4
MLM 76 n 12 12 1 3000	8.39	2.75	1.32	2725.7	471.2	235.6	23.3
MLM 76 n 12 12 1 6000	16.57	5.57	2.68	2725.7	471.2	235.6	43.9

n = number of flows

Category calculation for second group's fluids - Gas, melted gas and liquids with a steam tension at maximum temperature > 0.5 bar

Article 3.3

1st Category

2nd Category

MODEL	VOLUME [litres]	PRESSURE [bar] *												
		1	2	3	4	5	6	7	8	9	10	11	12	
MLM 76 n 12 12 1 1000	Shell / Tubes													
MLM 76 n 12 12 1 1500	Shell / Tubes											11.6		
MLM 76 n 12 12 1 2000	Shell / Tubes								8.8					
MLM 76 n 12 12 1 3000	Shell / Tubes					5.9								
MLM 76 n 12 12 1 6000	Shell / Tubes			3.0						8.9				12.0

* for higher pressure contact MBS

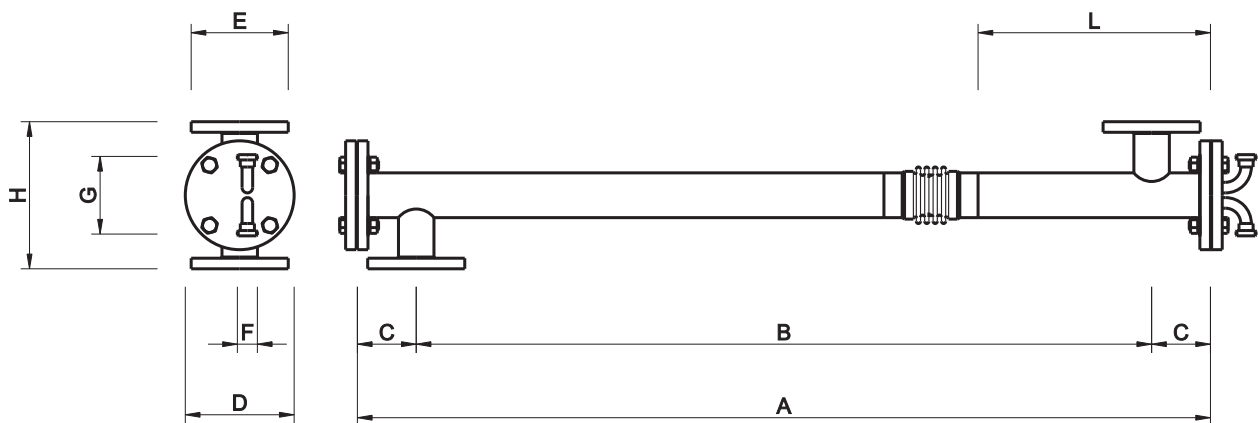

MODEL	DIMENSIONS [mm]								
	A	B	C	D	E	F	G	H	L
MLM 76 n 12 12 1 1000	950	750	100	EN 1092-1 DN 65 PN.16	EN 1092-1 DN 50 PN.16	DIN 11851 DN 15 F	132 WITH FLANGE 250	250	395
MLM 76 n 12 12 1 1500	1450	1250							
MLM 76 n 12 12 1 2000	1950	1750							
MLM 76 n 12 12 1 3000	2950	2750							
MLM 76 n 12 12 1 6000	5950	5750							

more connections
on demand

Not binding technical datas; may be modified by the Manufactures without advise

MODEL	SHELL VOLUME [litres]	TUBES VOLUME [litres]	EXCHANGE AREA [m ²]	SHELL SECTION [mm ²]	TUBES SECTION 2 PASSAGES [mm ²]	TUBES SECTION 4 PASSAGES [mm ²]	WEIGHT [kg]
MLM 88 n 16 12 1 1000	4.29	1.14	0.55	3851.6	628.3	314.2	12.2
MLM 88 n 16 12 1 1500	6.21	1.77	0.85	3851.6	628.3	314.2	16.5
MLM 88 n 16 12 1 2000	8.14	2.40	1.15	3851.6	628.3	314.2	20.8
MLM 88 n 16 12 1 3000	11.99	3.66	1.76	3851.6	628.3	314.2	29.4
MLM 88 n 16 12 1 6000	23.54	7.43	3.56	3851.6	628.3	314.2	55.2

n = number of flows

Category calculation for second group's fluids - Gas, melted gas and liquids with a steam tension at maximum temperature > 0.5 bar

Article 3.3

1st Category

2nd Category

MODEL	VOLUME [litres]	PRESSURE [bar] *												
		1	2	3	4	5	6	7	8	9	10	11	12	
MLM 88 n 16 12 1 1000	Shell / Tubes												11.6	
MLM 88 n 16 12 1 1500	Shell / Tubes								8.0					
MLM 88 n 16 12 1 2000	Shell / Tubes						6.1							
MLM 88 n 16 12 1 3000	Shell / Tubes				4.1									
MLM 88 n 16 12 1 6000	Shell / Tubes		2.1					6.7		8.4				

* for higher pressure contact MBS

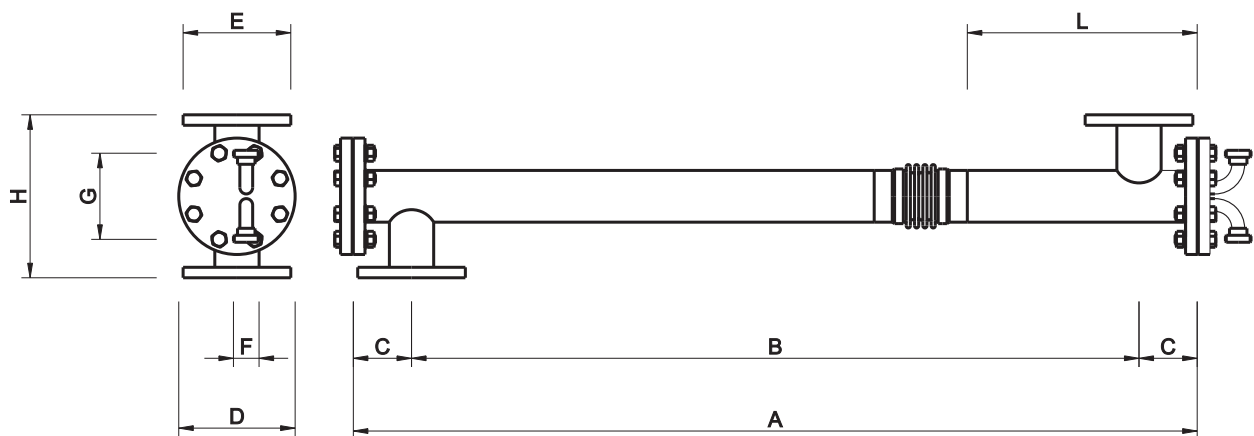

MODEL	DIMENSIONS [mm]								
	A	B	C	D	E	F	G	H	L
MLM 88 n 16 12 1 1000	950	750	100	EN 1092-1 DN 80 PN.16	EN 1092-1 DN 65 PN.16	DIN 11851 DN 20 F	148 WITH FLANGE 280	280	395
MLM 88 n 16 12 1 1500	1450	1250							
MLM 88 n 16 12 1 2000	1950	1750							
MLM 88 n 16 12 1 3000	2950	2750							
MLM 88 n 16 12 1 6000	5950	5750							

more connections
on demand

Not binding technical datas; may be modified by the Manufactures without advise

MODEL	SHELL VOLUME [litres]	TUBES VOLUME [litres]	EXCHANGE AREA [m ²]	SHELL SECTION [mm ²]	TUBES SECTION 2 PASSAGES [mm ²]	TUBES SECTION 4 PASSAGES [mm ²]	WEIGHT [kg]
MLM 114 n 32 12 1 1000	6.45	2.29	1.10	5936.1	1256.6	628.3	20.1
MLM 114 n 32 12 1 1500	9.42	3.54	1.70	5936.1	1256.6	628.3	27.2
MLM 114 n 32 12 1 2000	12.39	4.80	2.30	5936.1	1256.6	628.3	34.3
MLM 114 n 32 12 1 3000	18.33	7.31	3.51	5936.1	1256.6	628.3	48.5
MLM 114 n 32 12 1 6000	36.13	14.85	7.13	5936.1	1256.6	628.3	91.0

n = number of flows

Category calculation for second group's fluids - Gas, melted gas and liquids with a steam tension at maximum temperature > 0.5 bar

Article 3.3

1st Category

2nd Category

MODEL	VOLUME [litres]	PRESSURE [bar] *											
		1	2	3	4	5	6	7	8	9	10	11	12
MLM 114 n 32 12 1 1000	Shell / Tubes							7.7					
MLM 114 n 32 12 1 1500	Shell / Tubes					5.3							
MLM 114 n 32 12 1 2000	Shell / Tubes				4.0						10.4		
MLM 114 n 32 12 1 3000	Shell / Tubes		2.7					6.8			10.9		
MLM 114 n 32 12 1 6000	Shell / Tubes	1.3			3.3		5.5						

* for higher pressure contact MBS

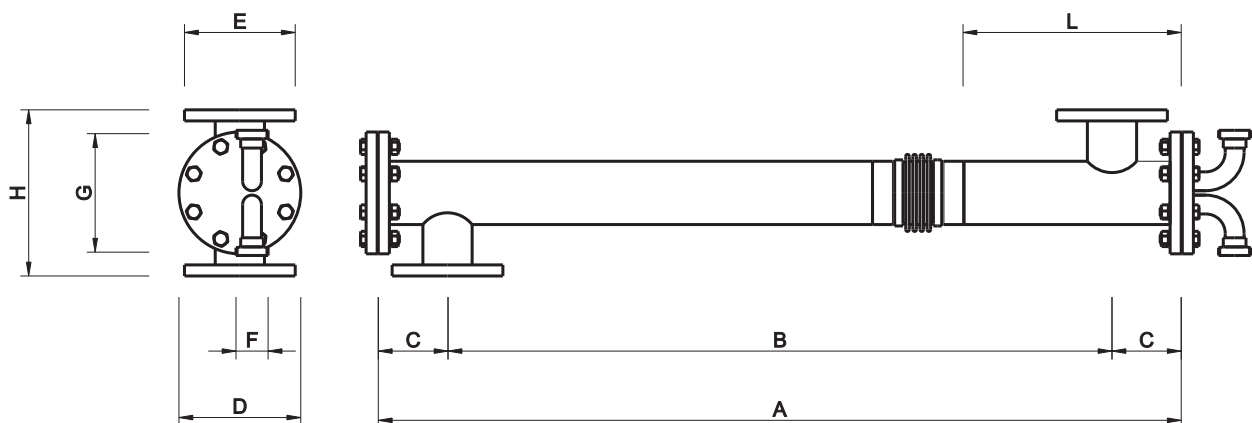

MODEL	DIMENSIONS [mm]								
	A	B	C	D	E	F	G	H	L
MLM 114 n 32 12 1 1000	950	750	125	EN 1092-1 DN 100 PN.16	EN 1092-1 DN 80 PN.16	DIN 11851 DN 32 F	214 WITH FLANGE 300	300	392.5
MLM 114 n 32 12 1 1500	1450	1250							
MLM 114 n 32 12 1 2000	1950	1750							
MLM 114 n 32 12 1 3000	2950	2750							
MLM 114 n 32 12 1 6000	5950	5750							

more connections
on demand

Not binding technical datas; may be modified by the Manufactures without advise

MODEL	SHELL VOLUME [litres]	TUBES VOLUME [litres]	EXCHANGE AREA [m ²]	SHELL SECTION [mm ²]	TUBES SECTION 2 PASSAGES [mm ²]	TUBES SECTION 4 PASSAGES [mm ²]	WEIGHT [kg]
MLM 139 n 48 12 1 1000	10.10	3.42	1.64	9034.0	1885.0	942.5	28.8
MLM 139 n 48 12 1 1500	14.62	5.30	2.54	9034.0	1885.0	942.5	38.7
MLM 139 n 48 12 1 2000	19.13	7.19	3.45	9034.0	1885.0	942.5	48.6
MLM 139 n 48 12 1 3000	28.17	10.96	5.26	9034.0	1885.0	942.5	68.3
MLM 139 n 48 12 1 6000	55.27	22.27	10.69	9034.0	1885.0	942.5	127.6

n = number of flows

Category calculation for second group's fluids - Gas, melted gas and liquids with a steam tension at maximum temperature > 0.5 bar

Article 3.3

1st Category

2nd Category

MODEL	VOLUME [litres]	PRESSURE [bar] *												
		1	2	3	4	5	6	7	8	9	10	11	12	
MLM 139 n 48 12 1 1000	Shell / Tubes				4.9									
MLM 139 n 48 12 1 1500	Shell / Tubes			3.4							9.4			
MLM 139 n 48 12 1 2000	Shell / Tubes		2.6					6.9				10.4		
MLM 139 n 48 12 1 3000	Shell / Tubes	1.7				4.5			7.0					
MLM 139 n 48 12 1 6000	Shell / Tubes			2.2	3.6						8.9			

* for higher pressure contact MBS

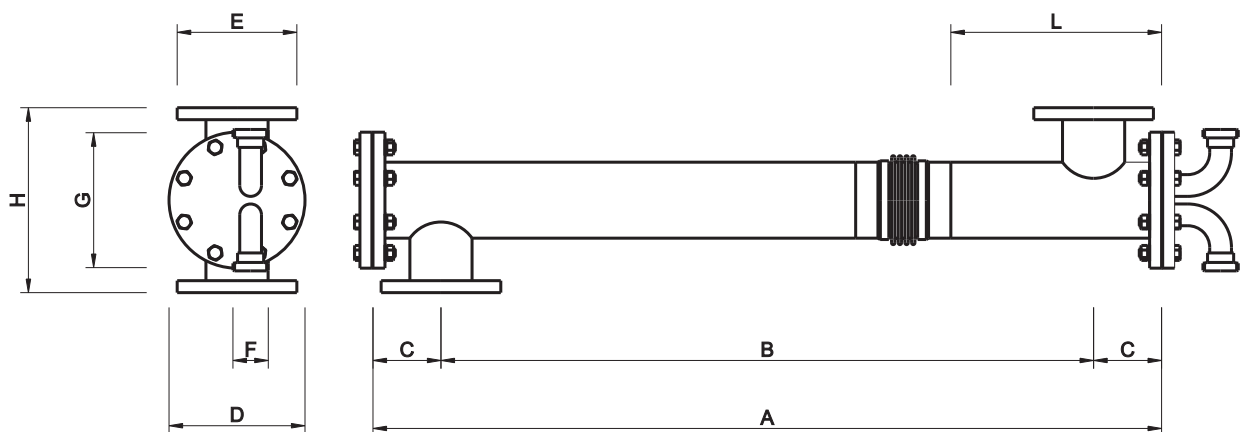

MODEL	DIMENSIONS [mm]								
	A	B	C	D	E	F	G	H	L
MLM 139 n 48 12 1 1000	950	750	125	EN 1092-1 DN 125 PN.16	EN 1092-1 DN 100 PN.16	DIN 11851 DN 40 F	248 WITH FLANGE 340	340	387.5
MLM 139 n 48 12 1 1500	1450	1250							
MLM 139 n 48 12 1 2000	1950	1750							
MLM 139 n 48 12 1 3000	2950	2750							
MLM 139 n 48 12 1 6000	5950	5750							

more connections
on demand

Not binding technical datas; may be modified by the Manufactures without advise

MODEL	SHELL VOLUME [litres]	TUBES VOLUME [litres]	EXCHANGE AREA [m ²]	SHELL SECTION [mm ²]	TUBES SECTION 2 PASSAGES [mm ²]	TUBES SECTION 4 PASSAGES [mm ²]	WEIGHT [kg]
MLM 168 n 76 12 1 1000	12.98	5.41	2.60	12093.0	2984.5	1492.5	45.5
MLM 168 n 76 12 1 1500	19.03	8.39	4.03	12093.0	2984.5	1492.5	61.9
MLM 168 n 76 12 1 2000	25.07	11.38	5.46	12093.0	2984.5	1492.5	78.3
MLM 168 n 76 12 1 3000	37.17	17.35	8.33	12093.0	2984.5	1492.5	111.0
MLM 168 n 76 12 1 6000	73.44	35.25	16.92	12093.0	2984.5	1492.5	209.3

n = number of flows

Category calculation for second group's fluids - Gas, melted gas and liquids with a steam tension at maximum temperature > 0.5 bar

Article 3.3 1st Category 2nd Category 3rd Category

MODEL	VOLUME [litres]	PRESSURE [bar] *														
		1	2	3	4	5	6	7	8	9	10	11	12			
MLM 168 n 76 12 1 1000	Shell / Tubes			3.8							9.2					
MLM 168 n 76 12 1 1500	Shell / Tubes		2.6				5.9					10.5				
MLM 168 n 76 12 1 2000	Shell / Tubes	1.9				4.3			7.9							
MLM 168 n 76 12 1 3000	Shell / Tubes	1.3		2.8			5.3								11.5	
MLM 168 n 76 12 1 6000	Shell / Tubes		1.4	2.7				5.6								

* for higher pressure contact MBS

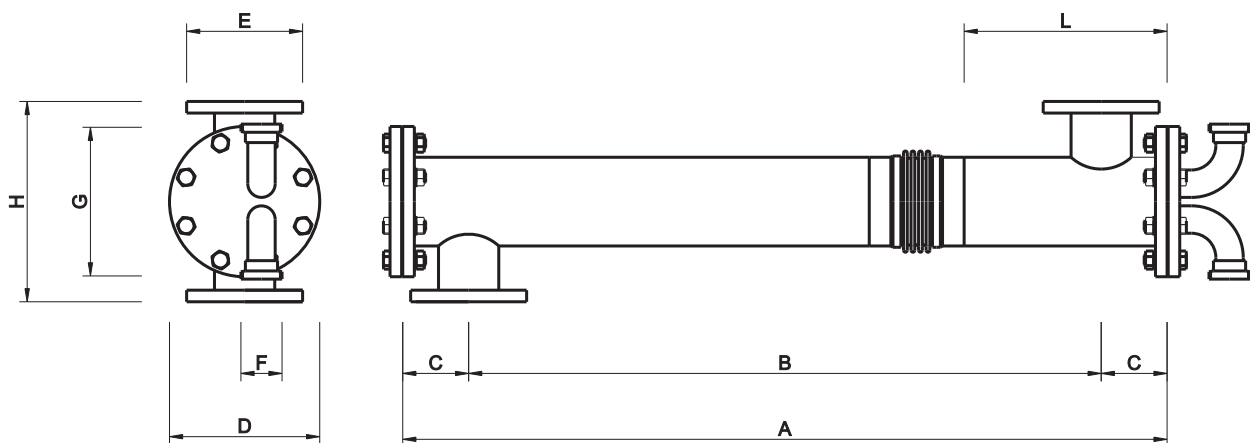

MODEL	DIMENSIONS [mm]								
	A	B	C	D	E	F	G	H	L
MLM 168 n 76 12 1 1000	950	750	125	EN 1092-1 DN 150 PN.16	EN 1092-1 DN 100 PN.16	DIN 11851 DN 50 F	282 WITH FLANGE 380	380	385
MLM 168 n 76 12 1 1500	1450	1250							
MLM 168 n 76 12 1 2000	1950	1750							
MLM 168 n 76 12 1 3000	2950	2750							
MLM 168 n 76 12 1 6000	5950	5750							

more connections
on demand

Not binding technical datas; may be modified by the Manufactures without advise

MODEL	SHELL VOLUME [litres]	TUBES VOLUME [litres]	EXCHANGE AREA [m ²]	SHELL SECTION [mm ²]	TUBES SECTION 2 PASSAGES [mm ²]	TUBES SECTION 4 PASSAGES [mm ²]	WEIGHT [kg]
MLM 219 n 144 12 1 1000	20.12	10.20	4.90	19447.2	5654.9	2827.4	76.6
MLM 219 n 144 12 1 1500	29.84	15.86	7.61	19447.2	5654.9	2827.4	104.1
MLM 219 n 144 12 1 2000	39.56	21.51	10.33	19447.2	5654.9	2827.4	131.6
MLM 219 n 144 12 1 3000	59.01	32.80	15.75	19447.2	5654.9	2827.4	186.5
MLM 219 n 144 12 1 6000	117.35	66.75	32.04	19447.2	5654.9	2827.4	351.2

n = number of flows

Category calculation for second group's fluids - Gas, melted gas and liquids with a steam tension at maximum temperature > 0.5 bar

Article 3.3 1st Category 2nd Category 3rd Category

MODEL	VOLUME [litres]	PRESSURE [bar] *												
		1	2	3	4	5	6	7	8	9	10	11	12	
MLM 219 n 144 12 1 1000	Shell / Tubes		2.4		4.9					9.9				
MLM 219 n 144 12 1 1500	Shell / Tubes	1.6		3.1			6.7							12.6
MLM 219 n 144 12 1 2000	Shell / Tubes	1.2	2.3			5.0					9.2			
MLM 219 n 144 12 1 3000	Shell / Tubes		1.5	3.3				6.0						
MLM 219 n 144 12 1 6000	Shell / Tubes	1.7	2.9							8.5				

* for higher pressure contact MBS

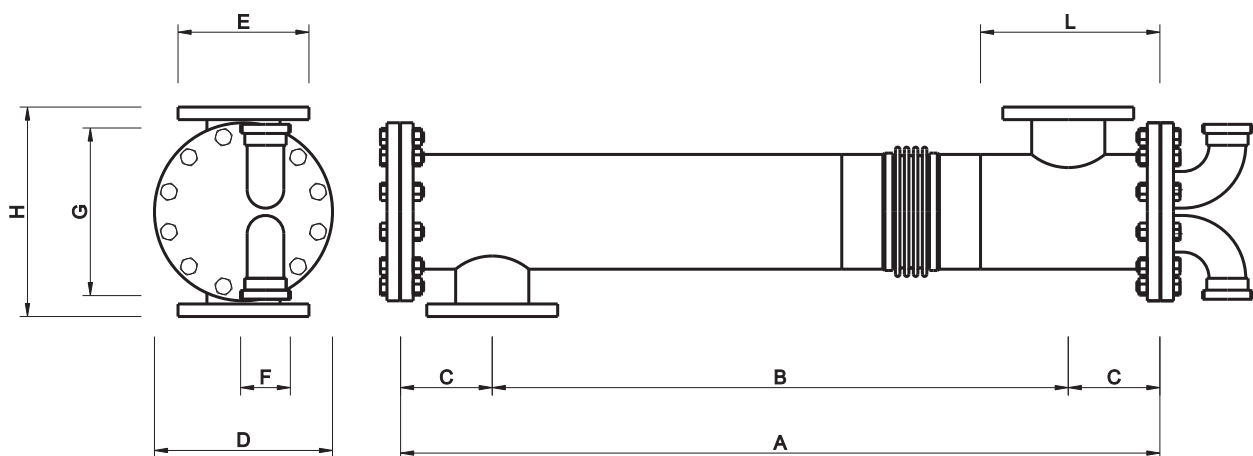

MODEL	DIMENSIONS [mm]								
	A	B	C	D	E	F	G	H	L
MLM 219 n 144 12 1 1000	950	750	175	EN 1092-1 DN 200 PN.16	EN 1092-1 DN 125 PN.16	DIN 11851 DN 65 F	320 WITH FLANGE 400	400	342.5
MLM 219 n 144 12 1 1500	1450	1250							
MLM 219 n 144 12 1 2000	1950	1750							
MLM 219 n 144 12 1 3000	2950	2750							
MLM 219 n 144 12 1 6000	5950	5750							

more connections
on demand

Not binding technical datas; may be modified by the Manufactures without advise

Codification

MLM	76	N	12	12	1	1500	D	F	T	A	A
										<p>Material</p> <p>Product / Service</p> <p>A - EN 1.4301 - AISI 304</p> <p>B - EN 1.4404 - AISI 316 L</p>	
										<p>Gaskets Material</p> <p>T - TEFLON</p> <p>W - WITHOUT ASBESTOS FREE</p> <p>R - GASKET'S REINFORCED GRAPHITE</p> <p>- GASKET'S NOT INCLUDED</p>	
										<p>Element connections</p> <p>Product / Service</p> <p>D - DIN 11851 - DIN 11864 - 1</p> <p>C - CLAMP ISO 2852 - ASME BPE</p> <p>- DIN 11864 - 2 - 3</p> <p>- DIN 32676</p> <p>C - CLAMP ISO 2852 - ASME BPE</p> <p>S - SMS</p> <p>B - BRITISH STANDARD MILK</p> <p>A - WELDING CONNECTION</p> <p>F - FLANGE EN - ANSI</p> <p>G - GAS UNI 338 - RJT</p>	
										<p>Lenght [mm]</p>	
										<p>Expansion joint</p> <p>0 - Excluded</p> <p>1 - Included</p>	
										<p>Product diameter [mm]</p>	
										<p>Inner tubes number</p>	
										<p>Number of passages</p>	
										<p>Sheet diameter [mm]</p>	
<p>Multitube version</p> <p>MLM - Total welded version</p>											